



伏赛电子有限公司
Fusign Electronics Co., Ltd

型号

EF-1602

REV	REVISIONS REC	DATE

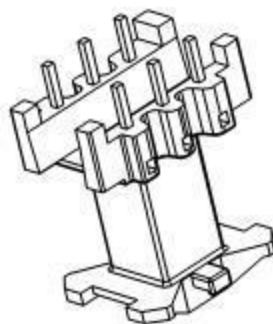
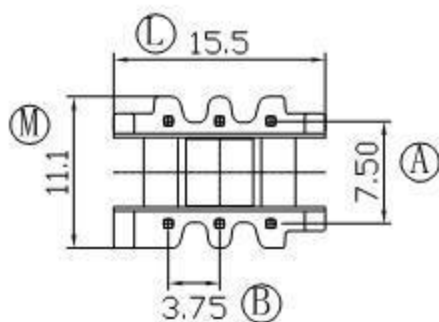
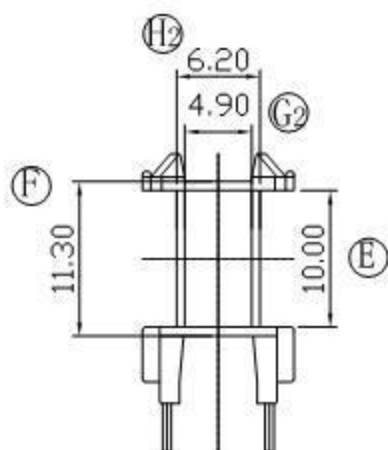
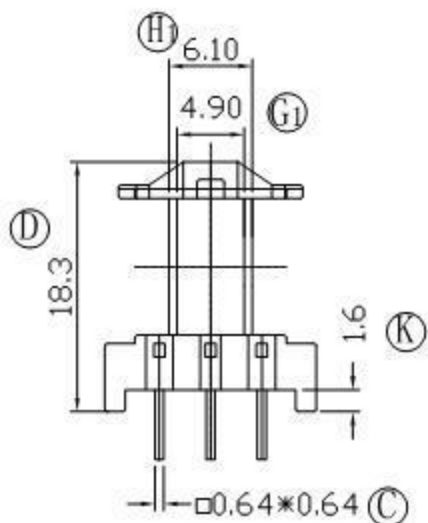
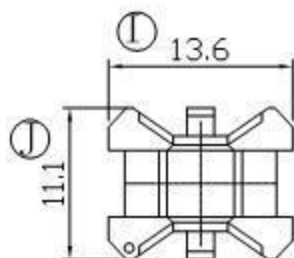

DRAWNBY	JING LI PENG	TOLERANCE	MODEL NAME:	EF16-6P-1S
CHECKER BY	LING RONG WANG	X, X ± 0.3	BOBBIN MATERIAL:	PET本色/NYLON红色
DATE	01-01-2008	X, XX ± 0.2	SCALE:	2:1
		壁厚: ± 0.15		SCALE: UL 94V-0
		PINPITCH ± 0.2		SCALE: M/M