

PCMCIA 10/100 Base – Tx LAN MAGNETICS MODULES

LAN-500

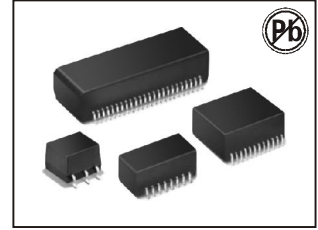

FEATURES:

- IEEE 802.3 Compliant
- PCMCIA

OPTIONS:

- Tape & Reel is Standard
- Custom design available

COMMON APPLICATIONS:

- PCMCIA LAN Card
- Type I & II Cards

STANDARD SPECIFICATIONS

Part Number	Turns Ratio $\pm 2\%$		Insertion Loss 1-100MHz (dB Max)	Cross Talk 0.1-100MHz (dB Min)	CMR 0.1-100MHz (dB Min)	Return Loss(dB Min)				Schematic	Package
	Tx	Rx				0.5-30MHz	50MHz	80MHz	60-80MHz		
LAN-501	1CT:1CT	1CT:1CT	1.1	35	30	18	15	13	11	1	A
LAN-502	1.41CT:1CT	1CT:1CT	1.1	35	30	18	15	13	11	1	A
LAN-503	1CT:1CT	1CT:1CT	1.1	35	30	18	15	13	11	2	B
LAN-504	1.41CT:1CT	1CT:1CT	1.1	35	30	18	15	13	11	2	B

- Primary OCL Tx & Rx: 350 μ H Min @ 100=8mA
- Hipot : 1500 VRMS

Schematic1(Ref Broadcom BCM5201 application)

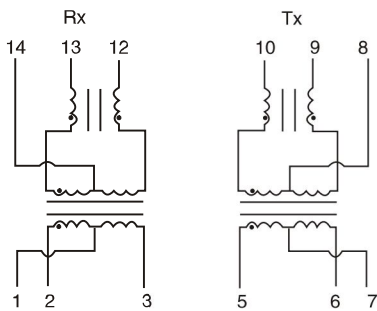

Dimension:Inch/mm

Package:A

Recommended Pod Layout

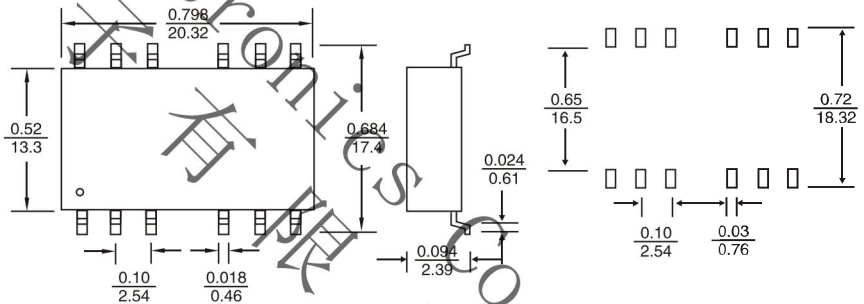

Schematic1(Ref Quilty Semi QS6612 application)

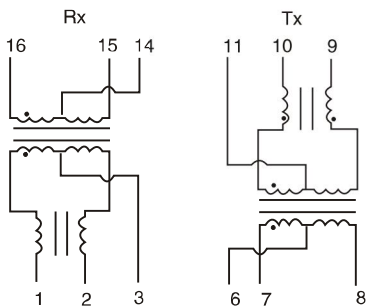

Package:B

Recommended Pod Layout

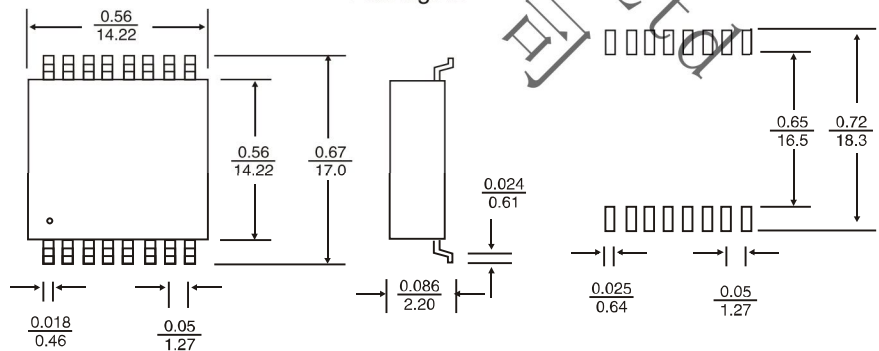

TECHNICAL INFORMATION:

- Soldering methods:Wave,Reflow
 - Operating Temperature: 0°C to 70°C
 - Storage Temperature: -55°C to 125°C
- Note:All specifications subject to change without notice.