



## THROUGH-HOLE AXIAL CONFORMAL COATED INDUCTORS

# LGA 0305 SERIES

### FEATURES:

- Ferrite Core
- Wire-wound construction
- Heat resistant epoxy resin
- High reliability, Ideal for automatic insertion
- Small size, Low Cost

### OPTIONS:

- Packaging: Tape & Reel is Standard (Qty: 1000 pcs)
- Bulk packaging available for smaller quantities
- Tolerance: 10% is standard, tighter tolerances available.

### COMMON APPLICATIONS:

- VCRs, PDP, LCD, TV set
- Automotive Systems
- Computer Peripheral Equipment
- GPS, DC/DC convertor, XDSL Modem
- Electronic Games
- Mobile Communications Equipment
- General Electronic Applications

### PHYSICAL CHARACTERISTICS

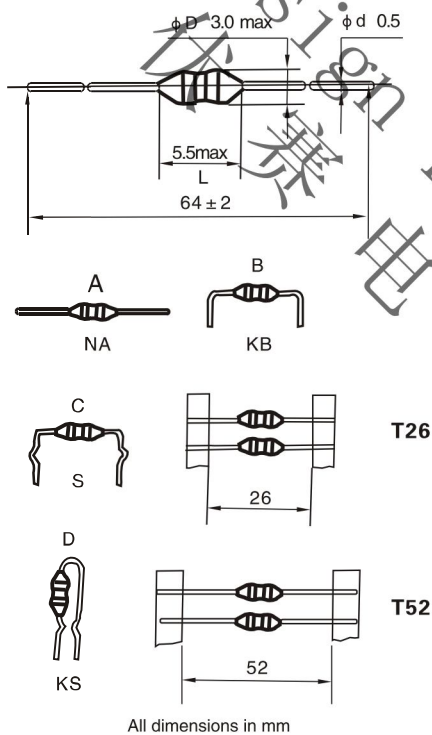

### STANDARD SPECIFICATIONS

Part Number	L (μH)	Tol ± %	Q min	L Test Freq (MHz)	S.R.F (MHz)	R <sub>DC</sub> (Ω) Max	I <sub>DC</sub> (mA)
LAG0305-R22K	0.22	20	35	25.2	150	0.40	400
LAG0305-R27K	0.27	20	35	25.2	150	0.43	380
LAG0305-R33K	0.33	20	35	25.2	150	0.48	370
LAG0305-R39K	0.39	20	35	25.2	150	0.51	350
LAG0305-R47K	0.47	20	35	25.2	150	0.56	330
LAG0305-R56K	0.56	20	40	25.2	150	0.61	320
LAG0305-R68K	0.68	20	40	25.2	150	0.67	310
LAG0305-R82K	0.82	20	40	25.2	150	0.74	290
LAG0305-1R0K	1.0	20	40	25.2	150	0.80	270
LAG0305-1R2K	1.2	20	50	7.96	144	0.90	260
LAG0305-1R5K	1.5	20	50	7.96	131	1.0	250
LAG0305-1R8K	1.8	20	50	7.96	121	1.1	240
LAG0305-2R2K	2.2	20	50	7.96	110	1.2	230
LAG0305-2R7K	2.7	20	50	7.96	100	1.3	220
LAG0305-3R3K	3.3	10	50	7.96	90	1.4	210
LAG0305-3R9K	3.9	10	50	7.96	60	1.6	200
LAG0305-4R7K	4.7	10	50	7.96	50	1.7	190
LAG0305-5R6K	5.6	10	50	7.96	42	1.9	180
LAG0305-6R8K	6.8	10	50	7.96	34	2.0	175
LAG0305-8R2K	8.2	10	50	7.96	25	2.2	165
LAG0305-100K	10	10	50	7.96	21	2.5	160
LAG0305-120K	12	10	50	25.2	19	2.5	150
LAG0305-150K	15	10	50	25.2	17	2.8	145
LAG0305-180K	18	10	50	25.2	13	3.1	140
LAG0305-220K	22	10	50	25.2	9.6	3.4	130
LAG0305-270K	27	10	50	25.2	7.2	3.8	125
LAG0305-330K	33	10	50	25.2	6.3	4.1	120
LAG0305-390K	39	10	50	25.2	6.3	4.5	115
LAG0305-470K	47	10	50	25.2	6.3	4.9	110
LAG0305-560K	56	10	50	25.2	6.2	5.3	105
LAG0305-680K	68	10	50	25.2	5.7	5.8	100
LAG0305-820K	82	10	50	25.2	5.3	6.3	95
LAG0305-101K	100	10	50	25.2	4.8	7.0	90
LAG0305-121K	120	10	50	0.796	3.8	13.0	90
LAG0305-151K	150	10	50	0.796	3.5	15.0	85
LAG0305-181K	180	10	50	0.796	3.3	16.0	80
LAG0305-221K	220	10	50	0.796	3.0	17.0	75
LAG0305-271K	270	10	50	0.796	2.8	19.0	65

### TECHNICAL INFORMATION:

#### 1. Ordering Code

LGA	04	10	KB	-	101	K	T52
(1)	(2)	(3)	(4)		(5)	(6)	(7)

- (1) Type
- (2) Outside
- (3) Body Length
- (4) Formed Type
- (5) Nominal Inductance
- (6) Inductance Tolerance
- (7) Tape Type

• Testing: (Equivalent acceptable)

Inductance-Hp 4285A  
RDC-QuadTech 1880 Milliohm-meter  
Q-HP 4342A  
SRF-HP 4191A

- IDC Max: The maximum DC value having inductance decrease within 10% and temperature increase within 20°C by the application of DC Bias
- Operating temperature: -25°C to +105°C
- Storage temperature: -40°C to +85°C
- Solderability: Temperature @ 230°C ± 5°C for 2 seconds
- Marking: EIA 4 band color code.

Note: All specifications subject to change without notice.

Note: 1. K = ± 10%, M = ± 20%