

HIGH CURRENT POWER INDUCTORS

PM 1004 SERIES

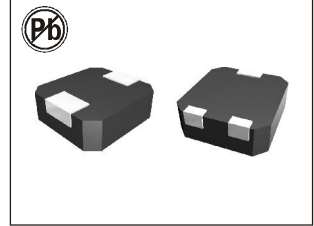

FEATURES:

- Lowest height in this package footprint.
- Shielded construction.
- Lowest DCR/H, in this package size.
- Handles high transient current spikes without saturation.
- Ultra low buzz noise, due to composite construction.
- Frequency up to 5MHz.
- The products contain no lead and also support lead-free soldering.

OPTIONS:

- Tape & Reel is Standard (Qty:900pcs.)
- Bulk packaging Available for Smaller Quantities
- Tolerance:M=20%, N=30% is Standard, Tighter Tolerances Available

COMMON APPLICATIONS:

- Excellent for power line DC-DC conversion
- Applications used in power switching
- Personal computers and other handheld electronic equipment.

ELECTRICAL CHARACTERISTICS:

Part Number	Thickness (mm)max.	Inductance L0(μH) ±20% @0A dc	I rms (A)	I sat (A)	DCR (mΩ)max.	Part Number	Thickness (mm)max.	Inductance L0(μH) ±20% @0A dc	I rms (A)	I sat (A)	DCR (mΩ)max.
MP 1004H-R36M	4.0	0.36	28	40	1.4	MP 1004H-2R2M	4.0	2.20	11.5	16.5	8.56
MP 1004H-R47M	4.0	0.47	26	38	1.6	MP 1004H-3R3M	4.0	3.30	10.0	14.0	10.0
MP 1004H-R56M	4.0	0.56	25	36	1.9	MP 1004H-4R7M	4.0	4.70	8.00	13.0	13.5
MP 1004H-R68M	4.0	0.68	23	32	2.4	MP 1004H-5R6M	4.0	5.60	7.00	12.0	16.0
MP 1004H-1R0M	4.0	1.00	20	28	3.5	MP 1004H-8R2M	4.0	8.20	5.00	8.00	32.5
MP 1004H-1R5M	4.0	1.50	12	20	7.5						

TECHNICAL INFORMATION & PHYSICAL CHARACTERISTICS:

- Test Frequency : 100KHz / 0.25Vdc
- Testing Instrument : L:HP4263B, CH3302, CH1320, CH1320S LCR METER/Rdc:CH16502, Agilent33420A MICRO OHMMETER.
- Heat Rated Current (I rms) will cause the coil temperature rise approximately, $\Delta T=40^{\circ}\text{C}$ without core loss.
- Saturation Current (I sat) will cause L0 to drop approximately 20%
- The part temperature (ambient + temp rise) should not exceed 125°C under worst case operating conditions. Circuit design, component, PCB trace size and thickness, airflow and other cooling provisions all affect the part temperature. Part temperature should be verified in the end application.
- Operating Temperature & Storage Temperature: $-40^{\circ}\text{C} - +105^{\circ}\text{C}$.

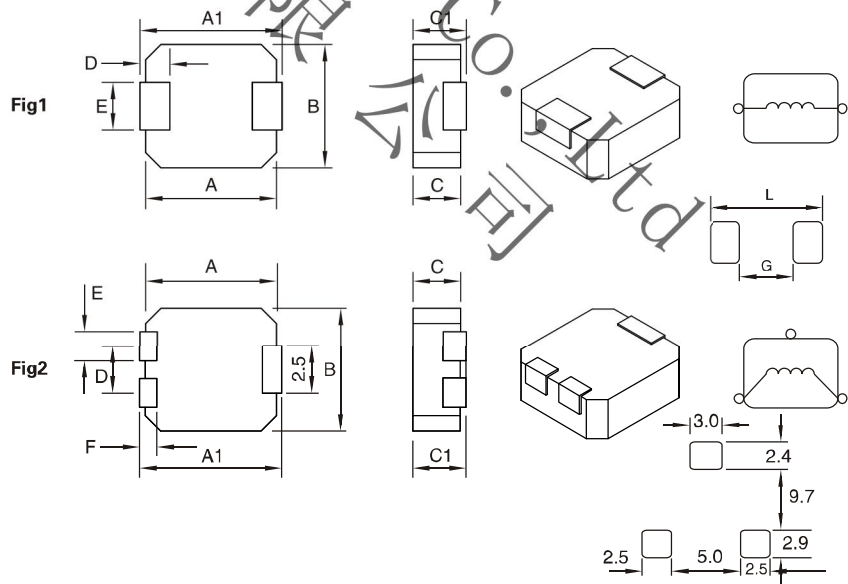

Dimensions(mm)

Series	A(mm)	A1(mm)	B(mm)	C(mm)	C1(mm)	D(mm)	E(mm)	L(mm)	G(mm)	H(mm)	Fig
PM 1004	10.7 ± 0.5	11.8 max.	10.5 max.	4.0 max.	4.2 max.	2.2 ± 0.5	2.9 ± 0.5	12.4	5.4	4.5	1