

SURFACE-MOUNT MULTI-LAYER CHIP BEADS

SBL 1005,1608 SERIES

FEATURES:

- Multilayer structure
- Closed magnetic circuit
- Avoids crosstalk
- Excellent magnetic shield
- Excellent solderability
- High reliability
- EMI/RFI suppression
- 20% impedance tolerance

OPTIONS:

- Packaging: Tape & Reel is standard (Qty:4000pcs)
Bulk packaging available for smaller quantities
- Impedance: Optional values available

COMMON APPLICATIONS:

- Cellular Phones
- Mobil Radios
- Cordless Telephones
- Modems
- Global Positioning Systems
- Wireless Communications Equipment
- Network Systems
- Computer Products

ELECTRICAL CHARACTERISTICS:

Part Number	IMPEDANCE (Ω) AT 100 MHz	DCR (Ω) Max	IDC Max mA	Part Number	IMPEDANCE (Ω) AT 100 MHz	DCR (Ω) Max	IDC Max mA
SBL1005A050H	5	0.045	500	SBL1608A050H	5	0.05	1000
SBL1005A070H	7	0.045	500	SBL1608A090H	9	0.05	1000
SBL1005A110H	11	0.05	500	SBL1608A110H	11	0.05	1000
SBL1005A190H	19	0.05	300	SBL1608A190H	19	0.05	1000
SBL1005A260H	26	0.15	300	SBL1608A260H	26	0.06	500
SBL1005A310H	31	0.20	300	SBL1608A310H	31	0.06	500
SBL1005A360H	36	0.20	300	SBL1608A600H	60	0.12	300
SBL1005A600H	60	0.35	200	SBL1608A700H	70	0.12	300
SBL1005A800H	80	0.40	200	SBL1608A800H	80	0.12	300
SBL1005A121H	120	0.50	150	SBL1608A101H	100	0.20	200
SBL1005A151H	150	0.55	150	SBL1608A121H	120	0.20	200
SBL1005A181H	180	0.60	150	SBL1608A151H	150	0.20	200
SBL1005A221H	220	0.70	100	SBL1608A181H	180	0.30	200
SBL1005A301H	300	0.80	100	SBL1608A221H	220	0.30	200
SBL1005A501H	500	1.1	100	SBL1608A301H	300	0.35	150
SBL1005A601H	600	1.3	100	SBL1608A501H	500	0.40	150
SBL1005A801H	800	1.4	50	SBL1608A601H	600	0.45	100
SBL1005A102H	1000	1.6	25	SBL1608A801H	800	0.50	100
SBL1005A122H	1200	1.8	25	SBL1608A102H	1000	0.60	100
				SBL1608A122H	1200	0.80	100
				SBL1608A152H	1500	0.90	50
				SBL1608A202H	2000	1.20	50

Note: 1. K = ± 10%, M = ± 20%

TECHNICAL INFORMATION

- Testing: Impedance vs. Frequency: HP 4195A
- Solderability: 90% of the terminal electrode shall be covered
Preheat: @ 260°C ± 5°C for 60 seconds
Flux: Rosin, Dip for 10 seconds ± 1 second
- Thermal Shock: Impedance shall be within ± 20% of initial value when temperature is -25°C and +85°C for 30 minutes for each 50 cycles
- Operating Temperature: -25°C to +85°C
- Storage Temperature: -25°C to +85°C

Note: All specifications subject to change without notice.

PHYSICAL CHARACTERISTICS

(Refer to Size Chart Page 4)

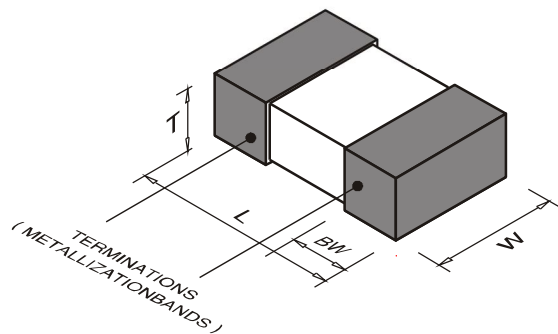

TERMINATIONS (METALLIZATION BANDS)