

**SURFACE-MOUNT TOROIDAL COILS AND COMMON MODE TOROIDAL CHORES**

**STC SERIES**

**STC-01, 02, 03, 04**

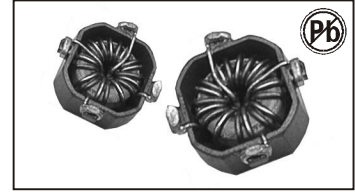

**FEATURES:**

- Higher Frequency
- High Saturation Material
- Low EMI Radiation
- Pick and PLace
- Low DC Resistance

**OPTIONS:**

- Tape and Reel is Standard
- Custom Design Available
- CMC Design Available
- Tolerance:20% is Standard
- Tighter Tolerances Available

**COMMON APPLICATIONS:**

- Electronic Appliances
- DC - DC Conversion (Paraller Mode)
- Isolation/Coupling(Transformer)
- Input Filter(Serial Mode)
- EMI/RFI Suppression

**STANDARD SPECIFICATION:**

Part Number STC-XX-	Parallel Ratings 01			Parallel Ratings 02			Parallel Ratings 03			Parallel Ratings 04		
	OCL nominal +/-25% ( $\mu$ H)	IDC A(max)	DCR $\Omega$ @20°C	OCL nominal +/-25% ( $\mu$ H)	IDC A(max)	DCR $\Omega$ @20°C	OCL nominal +/-25% ( $\mu$ H)	IDC A(max)	DCR $\Omega$ @20°C	OCL nominal +/-25% ( $\mu$ H)	IDC A(max)	DCR $\Omega$ @20°C
0.33	0.402	10.0	0.0092	0.284	10.9	0.0028	0.368	11.4	0.0027	0.313	12.2	0.0026
0.68	0.752	9.0	0.0039	0.675	9.4	0.0039	0.688	9.3	0.0041	0.744	10.6	0.0034
1.0	1.18	7.26	0.0060	1.26	8.22	0.0050	1.08	8.38	0.0051	1.39	9.23	0.0045
2.0	2.30	5.64	0.0110	1.98	6.74	0.0077	2.11	7.26	0.0068	2.18	8.38	0.0054
5.0	4.70	4.27	0.017	5.06	4.34	0.018	5.20	5.24	0.013	4.26	7.21	0.0073
8.0	7.94	3.37	0.028	7.90	3.50	0.027	8.43	4.23	0.020	8.70	5.49	0.013
10.0	10.58	2.84	0.039	11.38	2.89	0.040	9.68	3.64	0.027	10.53	4.67	0.017
15.0	15.23	2.07	0.075	15.48	2.69	0.046	15.52	3.25	0.033	14.70	3.87	0.025
20.0	20.73	1.71	0.109	20.22	2.24	0.067	20.81	2.43	0.061	19.58	3.62	0.029
25.0	24.86	1.46	0.148	25.60	1.89	0.095	24.77	2.34	0.065	25.14	3.02	0.041
33.0	34.26	1.22	0.213	34.84	1.56	0.138	33.71	1.93	0.096	34.80	2.49	0.061
50.0	51.18	0.99	0.327	49.38	1.28	0.206	48.71	1.56	0.147	50.11	2.05	0.089
68.0	67.87	0.92	0.375	66.44	1.07	0.293	68.80	1.28	0.217	68.21	1.70	0.131
100.0	99.45	0.74	0.588	102.38	0.75	0.596	99.07	1.05	0.325	100.57	1.37	0.201
150.0	147.4	0.67	0.713	152.9	0.68	0.722	149.7	0.86	0.489	153.5	1.10	0.313
200.0	198.6	0.62	0.825	197.5	0.64	0.814	198.8	0.71	0.711	200.4	0.92	0.447
300.0	300.8	0.56	1.012	303.7	0.58	1.006	296.2	0.56	1.122	302.8	0.75	0.675

**PHYSICAL CHARACTERISTICS**

**DIMENSIONS:INCHES**

**CONNECTION DIAGRAMS**

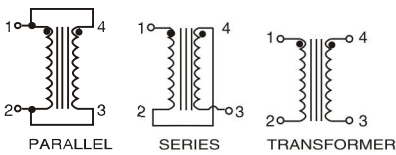

Case Size	A	B	C	D	E	F	G
STC-01	.350	.450	.165	.277	.422	.392	.145
STC-02	.350	.450	.235	.277	.422	.392	.145
STC-03	.450	.550	.190	.348	.492	.492	.160
STC-04	.450	.550	.250	.348	.492	.492	.160

*Dimensions in inches,typical*

**MECHANICAL DIAGRAM**

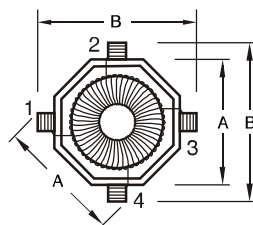
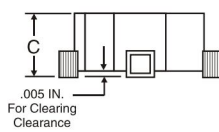

**BOTTOM VIEW**

**RECOMENDED LAYOUT**

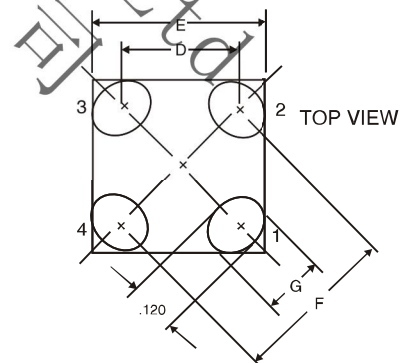

**TECHNICAL INFORMATION:**

- Inductance measure at 100KHz 0.1VRms.
- Insulation Resistance: 100Vdc 1KM $\Omega$  min.
- Turns Ratio: 1.1  $\pm$  0%
- RDC:QuadTech 1880 Milliohmmer
- Soldering temperature:260°C for 4  $\pm$  1 seconds
- Operating temperature:-40°C to +125°C
- Storage Temperature: -55°C to +125°C
- Different package available per special request
- Max of 35% saturation on DC bias applied

Note:All specifications subject to change without notice.